

Design Analysis and Implementation of Automatic Fire Extinguishing System Using ATmega16 Microcontroller as Control

Rilwanu Bello^{1*}, Bashir Abdullahi Sama¹, Nura Gambo² and Yusuf M. Ahijo³

¹Department of Science Technology, Waziri Umaru Federal Polytechnic, Birnin Kebbi, Kebbi State, Nigeria.

²Department of Physics, Isah Kaita College of Education Dutsin-Ma, Katsina State, Nigeria.

³Department of Physics, Usmanu Danfodiyo University, Sokoto, Sokoto State, Nigeria.

Authors' contributions

This work was carried out in collaboration among all authors. All authors read and approved the final manuscript.

Article Information

DOI: 10.9734/AJR2P/2021/v5i130155

Editor(s):

(1) Prof. Shi-Hai Dong, National Polytechnic Institute, Mexico.

Reviewers:

(1) Sirisha Potluri, India.

(2) Yusuf Suryo Utomo, Indonesia.

Complete Peer review History: <https://www.sdiarticle4.com/review-history/74050>

Original Research Article

Received 09 July 2021
Accepted 19 September 2021
Published 224 September 2021

ABSTRACT

Aim: The aim of this research is to design an automatic fire detection and control.

Methodology: The system consists of two sensors, microcontroller, buzzer and a pump/sprinkler. An LM35 integrated chip has been used as temperature sensor while MQ-2 gas sensor has been used as smoke sensor. All sensors are connected to the microcontroller through an input/output port. The controlling software for the whole system was designed in C programming language. The popular high performance, low power 8-bit microcontroller from the AVR family microcontrollers has been used. The system was finally tested by introducing fire parameters (smoke and temperature) close to the smoke and temperature detectors respectively. When the parameters go above the set level in the detectors, audio alarm, light indicator and pump/sprinkler were activated. The measured temperature of the system was compared with the reference temperature.

Results: The result showed that there was a mean deviation of 1.55°C between the measured values and reference values which served as the control.

Conclusion: The constructed system is compact and easy to install. The constructed fire control device is quite cheap and affordable to every category of person.

Keywords: Smoke sensor; temperature sensor; ATMEGA16 microcontroller; automatic control.

1. INTRODUCTION

The need for early fire detection is paramount in protecting human life and property as fire disaster is a great threat to lives and properties [1]. Fire is the rapid oxidation of a material in the exothermic chemical process of combustion, releasing heat, light, and smoke. It is understood that every fire start with a smoke and heat [2]. A key subject of interest to many researchers has thus been on firefighting systems. More interest has been given on automation of these systems to allow firefighting operation be less dependent on human support. Automated firefighting system, which depends on temperature and smoke sensing devices, is used in many industrial and commercial applications [3]. It is however true that in most cases sensible heat often occurs after great destruction has occurred and thus the use of smoke sensors need not be ignored at any point whatsoever. A number of fire detectors have been designed that can be installed within buildings. Among these types of sensors, the smoke sensor is widely used because of its early fire detection capability and its relatively low cost [4].

However, although this sensor provides rapid response time, it has high false-alarm rates. In contrast, the temperature sensor provides more reliable responses but with slow response time. Fire detectors that use a single sensor may fail to activate when required or may cause false alarms. Therefore, a fire detecting system that uses a combination of smoke and temperature sensors will not only provide better smoke sensor compensation but also provide a more intelligent fire control system [5].

The need to safeguard lives and properties from fire disasters has led to the invention of an automatic fire control system using a smoke detector, a heat detector and an automatic sprinkler [4]. Automatic fire alarm system provides an immediate surveillance, monitoring and automatic alarm. It sends early alarm when the fire occurs and helps to reduce the damage [6]. A smoke and heat detector is one of the numerous ways of detecting fire outbreak at an early stage, while a water sprinkler is the most common way of extinguishing fire. An automatic fire control system is an electronic circuit designed to control a sprinkler which produces water or any extinguishing element, when it detects the presence of smoke and excessive heat [7].

The automatic fire control system brings out efficient automatic fire detection and extinguishing system. The fire detection sensors will sense the occurrence of fire, by monitoring smoke and heat, which automatically generate a signal to interrupt the microcontroller which is connected to a buzzer and a pump. Suddenly after detecting the fire, the buzzer automatically sounds to indicate the presence of fire and starts the relay which runs a pump and pressurizes the extinguishing element to suppress the fire using water sprinkler. The role of the control unit in improving fire detection and control capability has already been recognized, with a system using control unit for decision making being one of two main versions of intelligent fire detection systems [8]. Automatic fire control systems have been made and installed in our buildings, which performed its specific functions accordingly. Both system activation (detection) and notification (alarm) must occur to achieve early warning [7].

2. METHODOLOGY

2.1 Automatic Fire Control System Design

Designing the system is the major part of this work and this involved the planning and estimation of the entire system before the actual implementation. Angus [9] designed an intelligent fire alarm system that utilized heat, smoke and infrared sensors. Computer control based system is made up of two important parts, hardware and software. Hardware provides the required signals to the computer in digital form and software within the computer analyses this signals to provide the desire output.

The block diagram comprises all the subsystems of the designed system, which consist of the power supply unit, smoke sensor, temperature sensor, microcontroller, pump/sprinkler, display/LED, and buzzer.

2.2 Power Supply Unit

The analysed automatic fire control system requires a DC voltage source for its operation. Therefore for the purpose of this design, an alternating (AC) voltage source of 220V will be used, where the AC voltage must be converted to DC voltage through rectification.

The power supply requiring voltage sources are the microcontroller, smoke sensor, temperature sensor and DC pump. The voltage requirement of these devices is specified in their datasheet to be 5 Volts each except DC pump that requires 12 Volts. Based on the specification 12 volts DC was designed for the whole system, and three 5V voltage regulators were connected to power the microcontroller and two sensors used. The idea of regulating and smoothing DC voltage was gathered from [10].

2.3 Temperature Sensing Device

The temperature sensor selected for this system was LM35DZ which is a precision integrated circuit temperature sensor made up of semiconductor materials, whose output voltage is linearly proportional to the Celsius (Centigrade) temperature. Mohammed *et al.* [11] conducted a research on thermal product of fast response temperature sensors for transient heat transfer applications, where they used sensor that has fast response time. The LM35 does not require any external calibration or trimming to provide typical accuracies of $\pm 1/4^{\circ}\text{C}$ at room temperature and $\pm 3/4^{\circ}\text{C}$ over a full -55 to $+150^{\circ}\text{C}$ temperature range. It is used with single power supply, as it draws only $60\mu\text{A}$ from its supply; it has very low self-heating less than 0.1°C in still air.

2.4 Smoke Sensing Device

GH-312 module (MQ-2) gas sensor was selected for this design because it is readily available in market, portable in size (suitable for embedded applications) and compatible to the designed

system. It is a gas sensing device which senses gases including smoke. The sensitive material of the sensor is Tin Dioxide, which with lower conductivity in clean air. The performance of ionization and photoelectric smoke alarms in various fire scenarios has been the great concern in detection part of the automatic fire control system [12]. MQ-2 gas sensing device is a PCB mounted type with two terminals; input and output.

2.5 Microcontroller

The selected microcontroller was ATMEGA16, because it is a low-power CMOS 8-bit microcontroller with 16KB in-system programmable flash based on the AVR enhanced RISC architecture, by executing powerful instructions in a single clock cycle [13]. The microcontroller serves as the central processing part of the system. It receives signal from smoke and temperature sensors, switches on an LED, buzzer alarm and the sprinkler system when smoke is sensed and also checks if the signal from the temperature sensor has surpassed the reference temperature.

2.6 Relay Circuit

HRS4-S-DC12V relay module was selected. The relay switches ON/OFF power to the premises and then sent to the DC pump. The relay circuit is connected to DC pump acting as the switching device when it receives signal from the microcontroller after the smoke sensor and the temperature sensor senses smoke and a high temperature respectively.

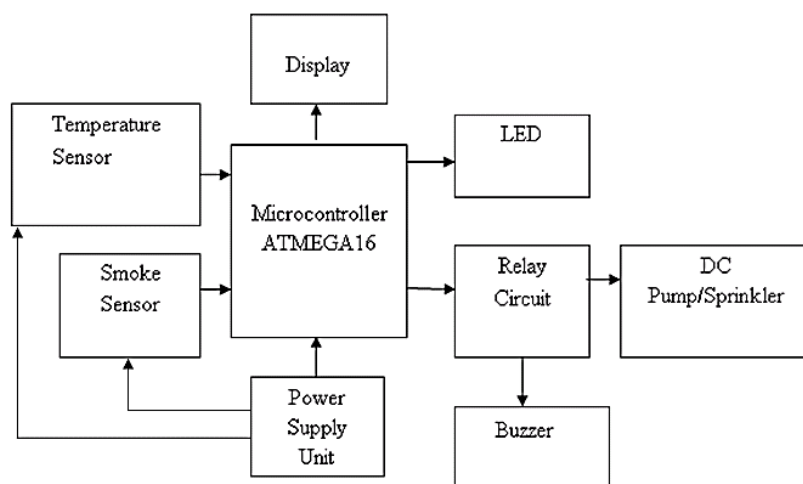

Fig. 1. Block diagram of automatic fire control system

2.7 Display Unit

The type of display used was a seven segment display. A bipolar junction BC557 PNP transistor for common anode display is use in order to drive the required display, which indicates the current situation of the system. It is connected to the microcontroller through input /output port with data and control lines. Abdulrahman et al. [14] designed and implement a simple seven segment display. The implemented circuit of the system shows how to connect simple input and output devices to a programmable chip.

2.8 Buzzer Alarm

The buzzer selected for this system was SV4/5-S PCB type, which is a PCB mounted type with two pins. The buzzer produces sound after the smoke sensor senses smoke and the temperature senses heat.

2.9 Pump/Sprinkler

The DC Pump used for this design was PAC Bosch with 12V DC, 3.8A operating power. The

outlet of the pump was attached to the end of a pipe which is also attached to the water sprinkler. The area which the water sprinkles depends on the type of sprinkler and also the pressure of the Pump. When sprinklers are present in the fire area, they operate in 93% of all reported structure fires large enough to activate sprinklers.

2.10 System Hardware Design

The relay, which runs the pump, was connected directly from rectified 12V DC supply and output signal that turn ON a relay was connected from PORT B (pin 7) of the microcontroller. The smoke sensor, temperature sensor and microcontroller were powered by 5V DC each through voltage regulators. Smoke sensor inputted signal through PORTA (pin 37), temperature sensor also connected through PORT A (pin 34) of the programmed microcontroller. Buzzer was connected to VCC and through 1 KΩ resistor from microcontroller IC to port B (pin 6). Three seven segment display was connected from PORT C (pin 22-29) and PORT D (14 and 15) of the microcontroller through 100Ω resistors. All these connections are illustrated as circuit diagram in Fig. 2

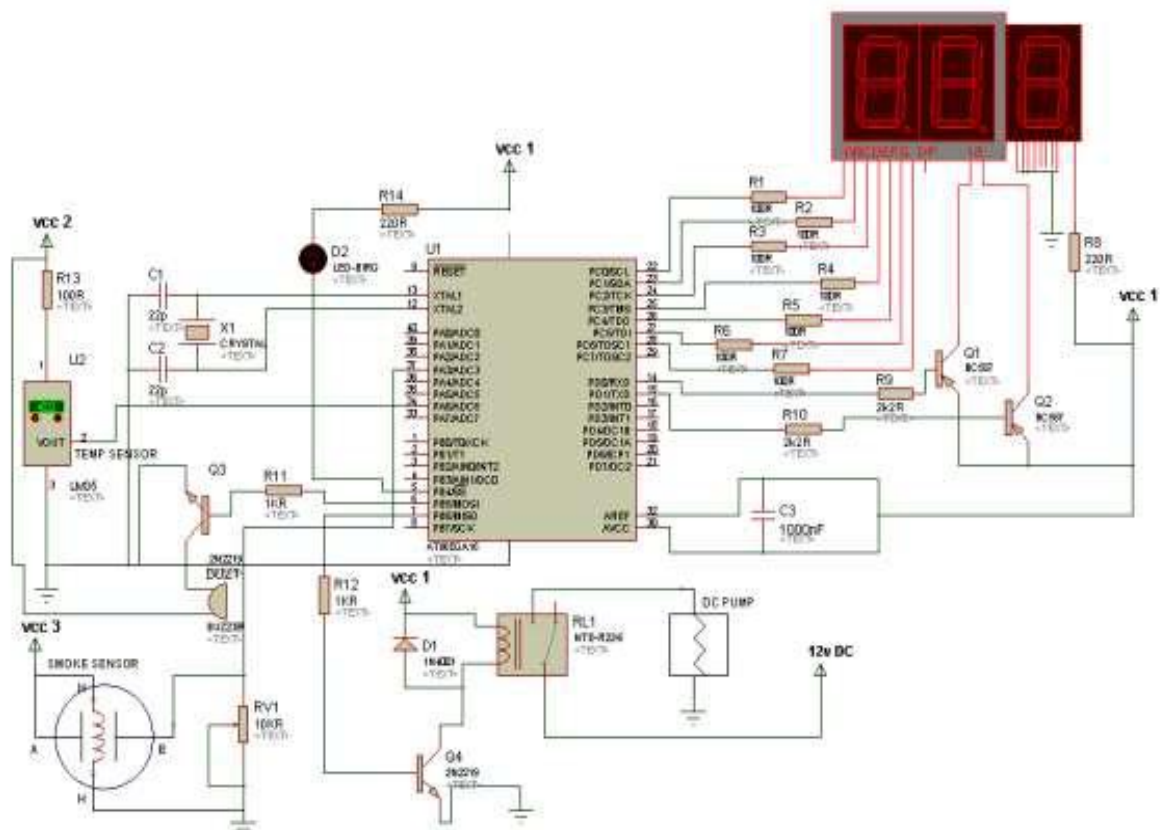

Fig. 2. Circuit diagram of automatic fire control system

2.11 Casing

The casing, housing of the entire circuit is a cuboids box made from plastic with several points on the box bored to accommodate and hold the LED, Temperature sensor, smoke sensor, Display and the buzzer. The casing will be measured 30cm x 30cm x 15cm.

2.12 System Software Design

In order to link the detected voltages from the sensors to the microcontroller and from microcontroller to the pump/sprinkler through a relay, C programming language was used as the communication protocol between hardware and software. Firstly, the input/output port of the microcontroller will be configured, such that both the status and the control lines act as inputs from the sensors.

2.13 Programming of Microcontroller

In order to program ATmega16 microcontroller, a special technique to load the program into the

microcontroller was followed. One of the methods was to use a microcontroller flash memory. Flash memory is similar to erasable programmable read-only memory. So the program was written and debugged using cross compiler. The compiled program was loaded to the flash memory of the microcontroller. Once program was flashed, the microcontroller was loaded with the hex code and it was ready for execution.

2.14 System Software Flow Chart

Fig. 3 shows the flowchart for the system software. When the program is running continuously the software set the status and control registers low and keep on monitoring for the presence of a high voltage in any of its pin. If a high voltage is detected in any of these lines, sprinklers will be activated through a relay circuit. When fire has been put off the software reads low at the input lines thus stopping the activated sprinkler.

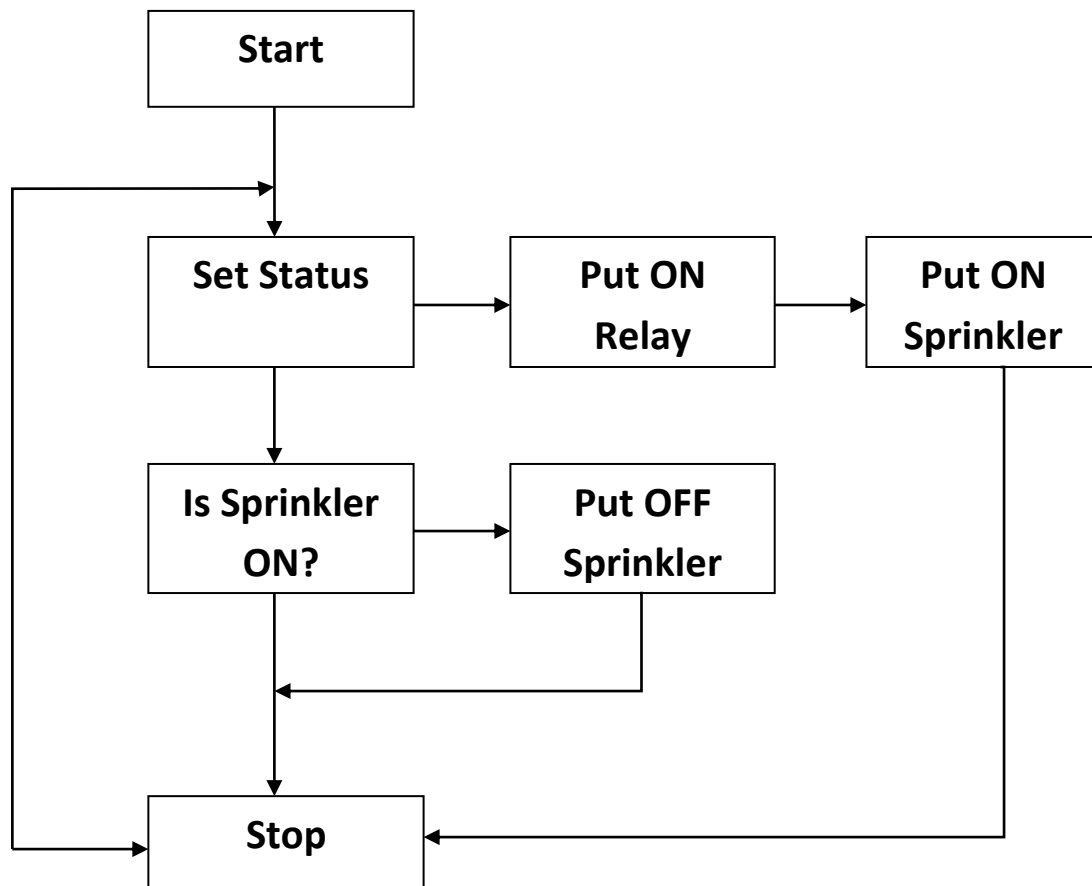

Fig. 3. Flow chat of system software

Table 1. Designed system response test results

| Test | Reference temperature | Operating temperature | Response time | LED | Buzzer | Pump |
|------|-----------------------|-----------------------|---------------|-----|--------|------|
| 1 | 50 °C | 54 °C | 21sec. | ON | ON | OFF |
| 2 | 55 °C | 58 °C | 19sec. | ON | ON | ON |
| 3 | 60 °C | 63 °C | 15sec. | ON | ON | ON |
| 4 | 65 °C | 66 °C | 11sec. | ON | ON | ON |
| 5 | 70 °C | 71 °C | 11sec. | ON | ON | ON |
| 6 | 75 °C | 76 °C | 9sec. | ON | ON | OFF |
| 7 | 80 °C | 81 °C | 7sec. | ON | ON | ON |
| 8 | 85 °C | 85 °C | 6sec. | ON | ON | ON |
| 9 | 90 °C | 90 °C | 6sec. | ON | ON | ON |

3. RESULTS AND DISCUSSION

A 100 watts soldering iron was introduced to the LM35 temperature sensor in order to raise the temperature until alarm was heard and LED turned ON and the DC pump. The response time was also found to be about 21 s for the selected temperature of 54 °C. Temperature sensor was found to respond to change in temperature at a slower rate compared to that of the smoke sensor. From the time that the pump was triggered on 21st second it took 50 s to completely suppress temperature below the set 54 °C in order to completely switch OFF the blinking LED, buzzer and DC pump. This time is about 30 s higher than that of the smoke sensor. The main cause of this is the slow cooling of LM 35 temperature sensor. It is thus evident that smoke sensors are more adequate for early fire detection though may be smooth to much false detection than temperature sensors. To observe the proper function of the designed system response to multiple inputs from the sensors (temperature and smoke), must be observed. Two sensor inputs were simulated by connecting 5 V to inputs of these sensors. These two generated signals must be together to interrupt the microcontroller. When only one signal was generated, there is no response from the system.

An automatic fire control device was designed and constructed. The system, which is microcontroller based is suitable for detecting fire (smoke and heat) within a given range, and activating display/ LED, DC pump and buzzer. The AC source from mains was converted in to DC voltage by the means of rectifier. The rectified voltage is a form of unfiltered electrical signal, which was filtered to lower the ripples of the rectified DC voltage using an LC filter. An ATmega16 series of microcontroller was configured and programmed using C programming language, to activate the activation part of the system (Display, buzzer and DC

pump). The system was activated after detecting smoke and heat through smoke and temperature sensing devices. After the construction, the system was subjected for tests to find out its performance. The power supply performance was found to meet the design specification. The response time of sensors was found to 11.7s, which is enough to control the fire without much destruction. The system/reference temperature was compared with the observed temperature, showed the mean error of 1.550C and consequently it was recommended that 1.550C should be added to any measurement of the system temperature values.

4. CONCLUSION

In this study an automatic fire control device has been designed and constructed, that could be of use in the building and construction sector. The fire control device was found to be working satisfactorily with low mean error and high accuracy. The constructed system is compact and easy to install. The constructed fire control device is quite cheap and affordable to every category of person. With the achievement of all the objectives of this research, we can conclude that the constructed device operates as expected, which is reliable and cost effective. The device should be employed in firefighting operations to help limit the number of death and property loss in our buildings.

5. RECOMMENDATIONS

Based on the result in this study these recommendations are suggested:

- The sensitivity of fire control device may be improved upon especially at large place to be monitored. It is therefore, recommended that a system that accepts many input from sensors may be designed. This may be possible by use of multiplexers.

- A rechargeable power supply unit may be incorporated in the constructed device to avoid power failure problems.
- The constructed device could further be enhanced by interfacing it to other firefighting equipment such as gas and powder extinguishers that can be used to different classes of fire.
- The designed software may also be used in areas outside fire control. These include object counters, burglar alarm, road traffic monitoring and other areas.
- Further work needs to be done to find other alternative sensors such as RTDs, thermistors, ionisation smoke detectors.

COMPETING INTERESTS

Authors have declared that no competing interests exist.

REFERENCES

1. Tedim F, Xanthopoulos G, Leone V. Forest fires in Europe: Facts and challenges. In Wildfire hazards, risks and disasters. Elsevier. 2015 Jan 1;77-99).
2. Salasinska K, Borucka M, Leszczyńska M, Zatorski W, Celiński M, Gajek A, Ryszkowska J. Analysis of flammability and smoke emission of rigid polyurethane foams modified with nanoparticles and halogen-free fire retardants. Journal of Thermal Analysis and Calorimetry. 2017 Oct;130(1):131-41.
3. Zahmatkesh F, Memari AM. Review of Conventional and Innovative Technologies for Fire Retrofitting of Existing Buildings. Open Journal of Civil Engineering. 2017;7(02):222.
4. Bukowski RW, Averill JD. Methods for predicting smoke detector activation. In Proceedings of a symposium entitled Fire Suppression and Detection Research, Research and Practice: Bridging the Gap, Orlando, FL 1998 Feb 25.
5. Cheon J, Lee J, Lee I, Chae Y, Yoo Y, Han G. A single-chip CMOS smoke and temperature sensor for an intelligent fire detector. IEEE Sensors Journal. 2009 Jun 30;9(8):914-21.
6. Zhang L, Wang G. Design and implementation of automatic fire alarm system based on wireless sensor networks. In Proceedings. The 2009 International Symposium on Information Processing (ISIP 2009). Academy Publisher. 2009;410.
7. Bukowski RW, Budnick EK, Schemel CF. Estimates of the operational reliability of fire protection systems. In Proceedings of the third international conference on fire research and engineering.. Society of Fire Protection Engineers. 1999 Oct 4;87-98.
8. Liu Z, Makar J. and Kim AK. Automatic fire detection. Proceedings of the 12th International conference on automatic fire detection conducted at National institute of standards and technology, Gaithersburg, Maryland, U.S.A.; 2008.
9. Angus M. The intelligent fire alarm. School of Information Technology and Electrical Engineering University of Queensland; 2002.
10. Mitra A, Roy A. A high regulated low ripple DC power supply based on LC filter & IGBT. International Journal of Power Electronics and Drive Systems. 2013 Mar 1;3(1):30.
11. Mohammed HA, Salleh H, Yusoff MZ, Campo A. Thermal product of type-E fast response temperature sensors. Journal of Thermal Science. 2010 Aug 1;19(4):364-71.
12. Cleary T. Performance of dual photoelectric/ionization smoke alarms in full-scale fire tests. Fire Technology. 2014 May 1;50(3):753-73.
13. Chauhan JS, Semwal S. Microcontroller based speed control of DC geared motor through RS-232 interface with PC. International Journal of Engineering Research and Applications (IJERA). 2013 Jan;3(1):778-83.
14. Abdulrahman A, Emhemed A. Implementation 7 segment display by educational board-software/hardware interfacing. Int J Eng Res Appl (IJERA). 2012;2:748-51. (John and Hall, 2010)

© 2021 Bello et al.; This is an Open Access article distributed under the terms of the Creative Commons Attribution License (<http://creativecommons.org/licenses/by/4.0>), which permits unrestricted use, distribution, and reproduction in any medium, provided the original work is properly cited.

Peer-review history:

The peer review history for this paper can be accessed here:
<https://www.sdiarticle4.com/review-history/74050>