



The Impact of Coolant Temperatures on Various Cycle Parameters of NH₃-H₂O Absorption Chiller from Solar Source

Adel Akair^{1*} and Hesham Baej¹

¹*Department of Mechanical Engineering, Higher Institute of Sciences and Technology, Libya.*

Authors' contributions

This work was carried out in collaboration between both authors. Author AA designed the study, performed the statistical analysis, wrote the protocol and wrote the first draft of the manuscript. Author HB managed the analyses of the study. Both authors read and approved the final manuscript.

Article Information

DOI: 10.9734/JENRR/2021/v7i130183

Editor(s):

(1) Dr. K. J. Sreekanth, Kuwait Institute for Scientific Research (KISR), Kuwait.

Reviewers:

(1) Debrayan Bravo Hidalgo, Sharing Knowledge Group (SKG), Ecuador.

(2) K. Kanimozhi, Sethu Institute of Technology, India.

Complete Peer review History: <http://www.sdiarticle4.com/review-history/65029>

Received 25 November 2020

Accepted 24 January 2021

Published 17 February 2021

Original Research Article

ABSTRACT

The cycles' structure was based on recently published technical information of low-temperatures powered Ammonia-water (NH₃-H₂O) absorption chiller. The cycle was completely modeled using different components available within the refrigeration library of IPSEpro software package. Using the model a cold-water ammonia-water absorption chiller was examined and validated in accordance to the relevant thermodynamic laws and charts. A low-grade temperature solar resource was modeled to energise the proposed model. For water-cooled cycles, the rejected heat from the absorbers and the condensers was carried out by water, at an average fixed temperature of 25°C, pumped out from ground water. The results obtained show that when the Coefficient of performance (COP), heat inputs into the generator, and cooling mass flow rates are fixed, the cycle parameters are highly affected by variation of coolant temperature. For instance when cooling water temperature decreases. Also when cooling water temperature increase, the cycle pressure, usable chilled water temperature difference and desorber outlet temperature increase whereas mass concentration and refrigeration capacity decrease. The effectiveness of the generator inlet temperature (solar source) is a factor of the largest effect to the COP. The

*Corresponding author: E-mail: adel_akker@yahoo.com;

difference was 0.1401, 27.4%. The chilled water inlet temperature (underground water) is the second largest effect to the COP. The difference between the maximum and the minimum value is 0.0865 and the relative difference is 18.9% with cooling capacity 12 kW. The influence of evaporator temperature to the COP is also minimal with only 2.2% difference. The influence of absorber temperature and condenser temperature to the COP are almost identical, the relative difference is 19.2% and 18.9% respectively.

Keywords: Solar source; IPSEpro; Ammonia / water absorption chiller.

1. INTRODUCTION

This is a study into the possibility and application of ammonia-water ($\text{NH}_3\text{-H}_2\text{O}$) absorption chiller technology, driven by the sun's heat (as well as other low-grade heat sources), some results has been published in manuscript [1]. To generate power and cooling by computer simulations and experimental tests [2], and solar cooling [3], for Application of solar [4]. Development Solar absorption cooling with low grade heat source. The effects of difference temperatures on the components and cop. The ambient temperature increases will change the cooling capacity and COP value [5]. It is more effective to use underground water in hot environments but in Water-cold (cooling water) the ground water temperature will have an effect on the cooling capacity and COP value, the model using IPSEpro a process is a network of discrete components and their connections that can represent any system. Graphically, each component is represented as an icon. The icons are connected appropriately through connections that indicate how the working media is flowing from the outlet of an icon must be the same as the ones at the inlet of the next icon. The key to IPSEpro's flexibility is its concept of model libraries. With IPSEpro, models of process schemes can be created using components from a standard library, or using components created by the user [6]. IPSEpro system structure and how the modules of the package interact with each other, [7]. The modeling concept is based on three different process components connected hierarchically. IPSEpro restricts how objects of different component models can reference each other. An absorption cycle using ammonia-water mixture working fluid is perhaps the simplest manifestation of such a cycle is provided in Fig. 1. The components and the streams are labeled, and the state points in the connecting lines are assigned state point numbers.

2. MODEL DESCRIPTION AND PROCESSES

Point (10) is a low-pressure refrigerant vapour that enters the absorber. The solution leaving the absorber part comprises a high concentration level of refrigerant (1) that has a weak capability to absorb the refrigerant liquid; this is pumped with the necessary pressure from the generator (4). This increases the solution temperature and the quantity of refrigerant stored within the absorbent is reduced. The low concentrated refrigerant solution remaining in the generators described as a strong solution (ability to absorb the refrigerant) from the explanation by [8] and Heating, Refrigating and Air-conditioning [9]. The strong solution at point (11) will return to the absorber. The high temperature and pressure refrigerant vapour (5) leaves the generator and goes to the rectifier, after which it will enter the condenser point (7). This results in a decrease in the temperature that condenses it into a liquid (8). The refrigerant will pass through an expansion valve, resulting in a decrease in the evaporator pressure (9). The refrigerant vapour in point (10) will leave the evaporator and return back to the absorber for complete the cycle. Fig. 1 shows the liquid sub-cooler and solution heat exchange. A conclusion of the state point's explanation is shown in Table 1. As listed in the table, three points are saturated liquid (1, 8, and 13), three are sub-cooled liquid (2, 4, and 12) one is saturated vapour (10), one is superheated vapour (7), two are two-phase vapour-liquid states (9) and (11), providing a total of ten state points. The model was validated using the results from [10].

3. CYCLE SENSITIVITY ANALYSIS

According to [11] and from high number of successful simulated trials which have been carried out during the modeling stage of this study, the most common variables, that have an influence on the other cycle parameters, were: the generator inlet temperature (T14), the inlet

chilled water temperature (T25) and the coolant temperatures (T21&T23). The variations of the generator and the chilled water inlet temperatures are discussed in the following two paragraphs, while an effect of variation of the coolant temperatures, for water cooled absorption chillers, is presented at the end of this chapter as a separate section and contains a comprehensive parametric study.

3.1 Influence of Generator Inlet Temperature Variations

A simple example of the interdependence of all operating variables can be obtained by varying the generator inlet temperature coming from the solar source while holding all other inputs constant (defined in Table 2), except the

generator outlet temperature (T15) which was fixed at 93.6°C. As shown in Figs. 1 the simulated models were successfully run within a small generator inlet temperature range of 70-180°C without touching the crystallisation line or violation. The generator outlet temperature (T15) is fixed at a temperature of 93.6° C and the influence of the generator inlet temperature variation (T14) on the chiller COP is clearly shown in Fig. 2. The COP was increased from approximately 0.3463 at a temperature of 70°C to reach the maximum value of 0.5121 at the inlet generator temperature of 180°C, a difference of 0.1401; the relative difference was 0.274, 27.4%. This increase in the COP value was due to the range of the inlet generator temperature.

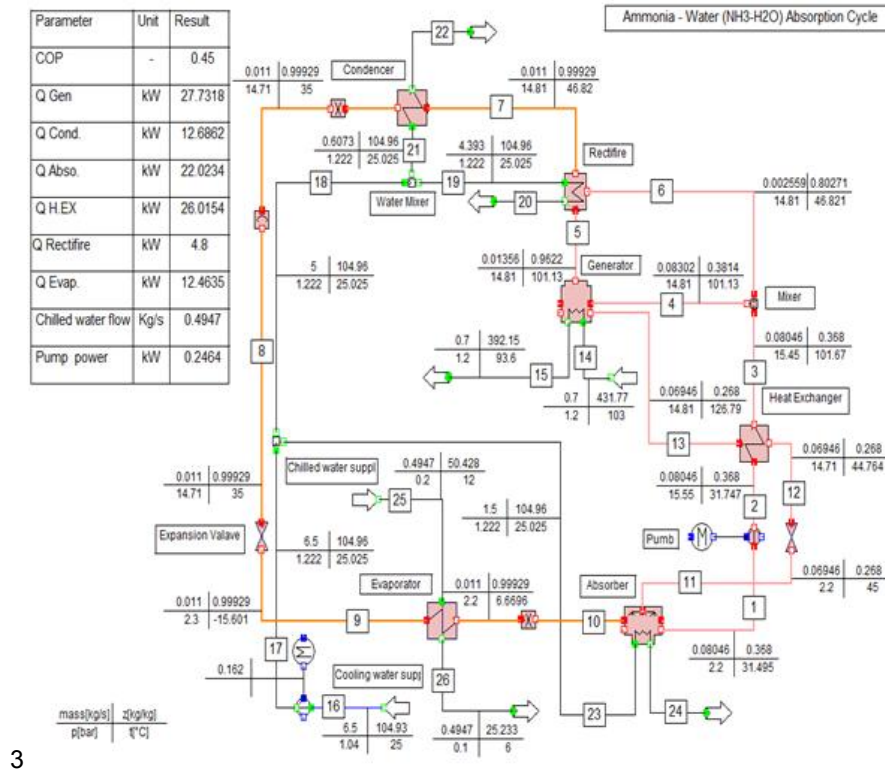

Fig. 1. Schematic diagram of the water-cooled absorption chiller

Table 1. Model thermodynamic state points summary

Point	State	Point	State
1	Saturated liquid solution	11	Vapour-Liquid solution state
2	Sub-cooled liquid solution	7	Superheated ammonia vapour
4	Sub-cooled liquid solution	8	Saturated liquid NH3
13	Saturated liquid solution	9	Vapour-Liquid mixture NH3
12	Sub-cooled liquid solution	10	Saturated NH3vapour

Fig. 3. shows the refrigeration capacity from a low value of approximately 6.8 kW at 70°C to reach 18.6 kW at 180°C. Therefore, for this project the COP value is 0.39 at a temperature 103°C, a difference of 11.8. The increase of the capacity was due to the high potential heat transferred from the heat input source to the chiller components. The higher the heat input into the generator the higher the ammonia/water mixture circulation ratio, and hence the higher the refrigeration capacity obtained.

3.2 Influence of Evaporator Temperature Variations

Fig. 4 presents the influence of the evaporator temperature to the system COP. Along with an increase of the evaporator temperature, the COP also increases from 0.9323 at a temperature of -20° C to 0.4227 at a temperature of 5° C. This proves the fact that the lower the evaporator temperature, the lower the system COP (difference of 2.2%).

3.3 Influence of Absorber Temperature Variations

Fig. 5 presents the influence of the absorber temperature to the system COP. The figure

shows that the COP of the system will drop as the absorber temperature increases, a COP value from 0.4577 at 15°C of the absorber temperature descends to 0.3712 at 40°C of the

absorber temperature. The value of COP between the maximum and the minimum is 0.1890 and the relative difference is 18.9%.

3.4 Influence of Condenser Temperature Variations

Fig. 6 represents the influence of condenser temperature to the system COP. The COP drops along with the increase of the condenser temperature. The value of COP descends from 0.4719 at the condenser temperature of 15°C to 0.3811 at the temperature 40°C. The difference of COP between the maximum and the minimum is 0.192 and the relative difference is 19.2%.

3.5 Influence of Chilled Water Inlet Temperature Variations

Fig. 7 presents an effect of the inlet chilled water temperature variations on the chiller COP and cooling capacity. A small linear increase in the COP, compared with that obtained due to the difference was 0.1659 in Fig. 2 of the generator inlet temperature was in range (70-180°C). During the increase of the inlet chilled water temperature and while fixing the generator input temperature at 103°C, the COP increased linearly. The difference of COP between the maximum and the minimum is 0.0865 and the relative difference is 18.9%.Both the numerator and the denominator values of the COP increased due to the increase of the generator and the evaporator heat transfer.

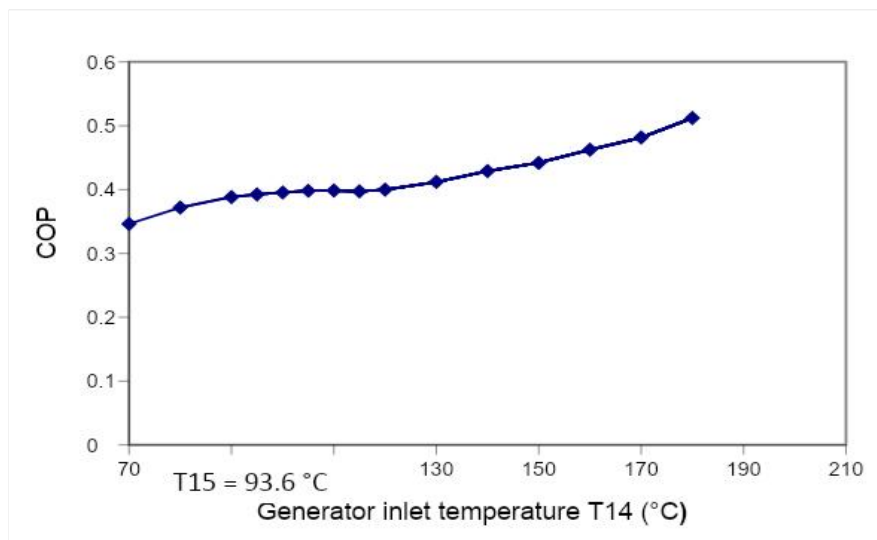

Fig. 2. Effects of the generator inlet temperature on the COP

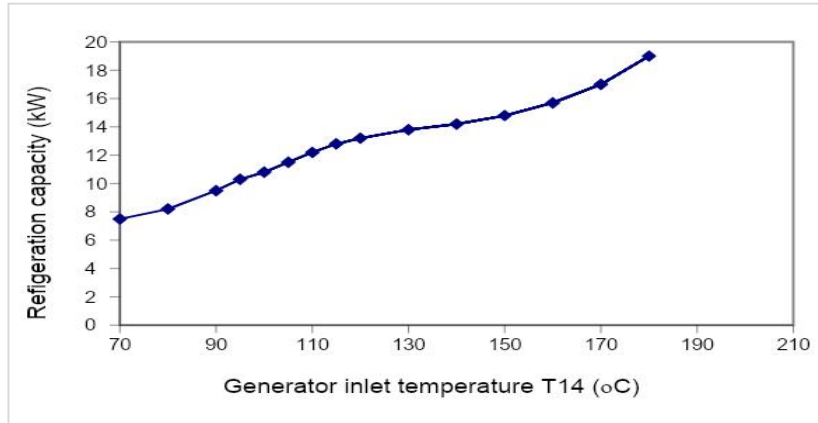

Fig. 3. Effects of the generator inlet temperature on the refrigeration capacity

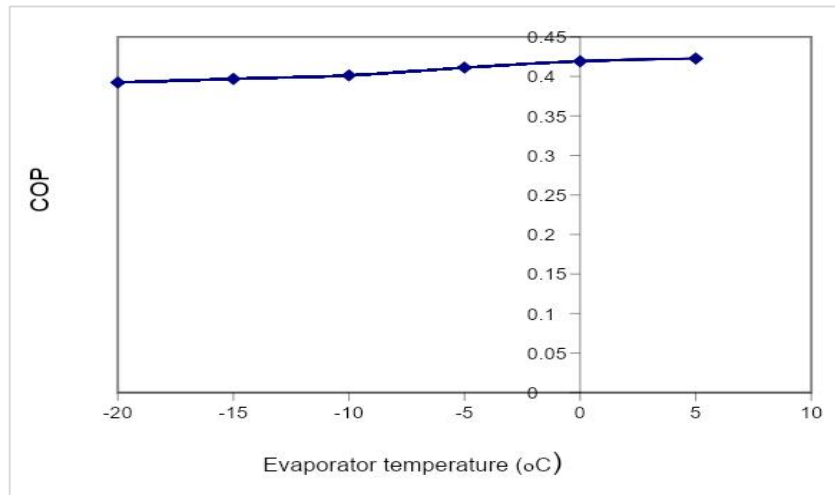

Fig. 4. Effects of the evaporator temperature on the COP

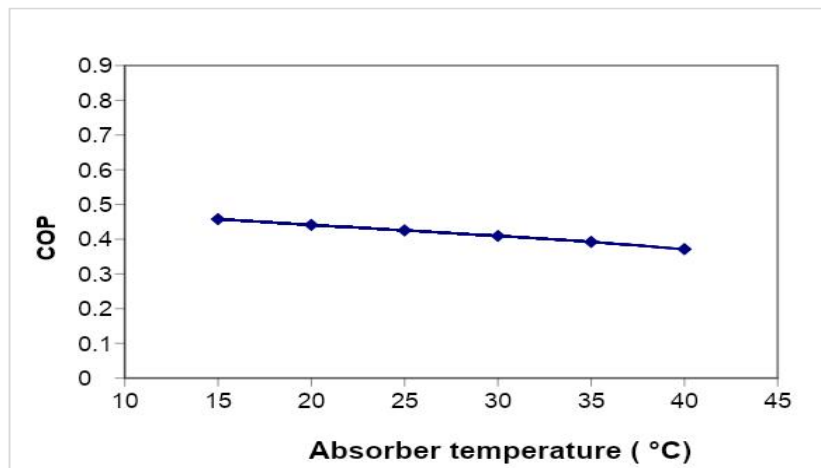

Fig. 5. Effects of the absorber temperature on the COP

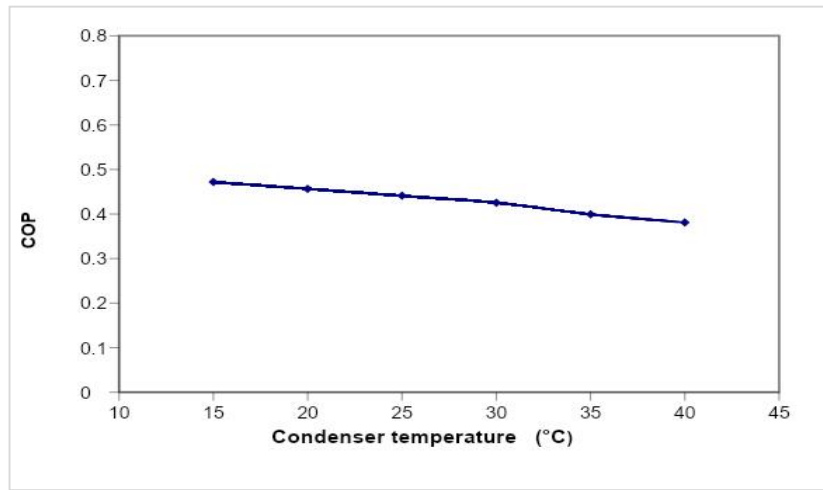

Fig. 6. Effects of condenser temperature on the COP

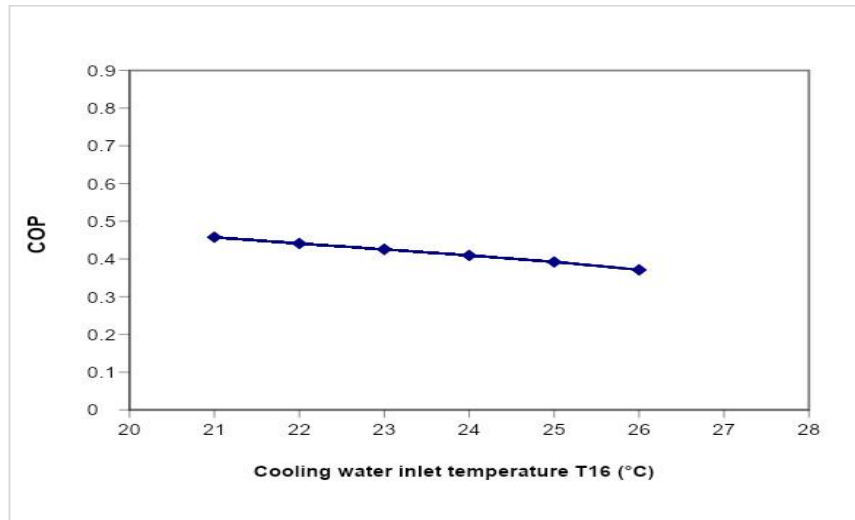

Fig. 7. Effects of the cooling water inlet temperature on the COP

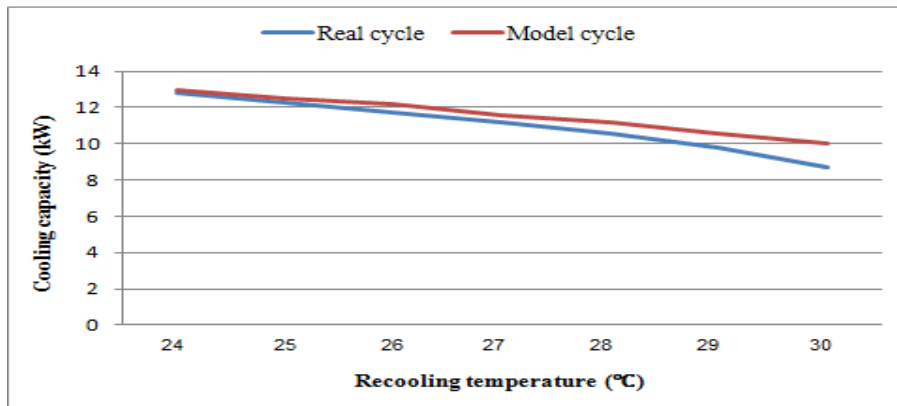

Fig. 8. Recooling temperature (°C) real/model with cooling capacity (kW)

Table 2. The water cooled Ammonia-water absorption chiller output results

Description	Unit	Result	Description	Unit	Result
COP	-	0.45	Condenser UA	kW/K	1.11
Rectifier heat transfer	kW	4.8	Evaporator UA	kW/K	1.07
H.EX heat transfer	kW	26.01	Solution H.E. UA	kW/K	1.41
Heat energy input	kW	27.7	Mass flow rate input	kg/s	0.7
Absorber heat	kW	22.02	Solution circulation pump power	kW	0.24
Condenser heat	kW	12.68	Cooling water mass flow	kg/s	6.5

For the cycle heat exchanger components, Table 3 below presents the calculated Number of Transfer Units (NTU) and the effectiveness (ϵ)

Table. 3 NTU and ϵ of the absorption cycle heat exchangers

Heat Exchanger component	Number of transfer Units (NTU)	Effectiveness (ϵ)
Condenser	1.64	0.806
Evaporator	1.27	0.72
Hot water supply (Compact heat exchanger)	3.47	0.81

From the results above, it can be seen that any changes in any one of the system parameters will cause a change in the performance of the overall system

3.6 Influence of Recooling Temperature Variations (Real / Mode)

The following effects of recooling on the cooling capacity are noted; when the inlet recooling water temperature increases both the cooling capacity and COP will decrease. This occurs in the real and model cycles when the ambient temperature is fixed. The increase in the recooling water inlet temperature, over relatively small temperature range between (24-27°C), has a major influence on the cooling, with model validation was carried out using equipment [12], manufactured by a company called Solar next capacity. Increasing the recooling water inlet temperature by only 4 degrees Fig. 8 causes the cooling capacity to decrease from 13.1 kW to 11.7 kW for the real cycle and in the model cycle from 13.3 kW to 11.9 kW. Considering the range between 27-30°C (Figure 6.9), the cooling capacity of the real cycle decreases from 11.2 kW to 8.7 kW with a difference of 2.5 kW and model cycle from 11.4 kW to 10 kW, with a difference of 1.1 kW. The difference between the real and model cycles was 1.4.

4. RESULTS AND DISCUSSION

The obtained parametric results, of the proposed chiller model, such as the coefficient of performance (COP), the refrigeration capacity, the main cycle components heat transfer, the hot water supply energy, the cooling water mass

flow, the components heat transfer coefficient area, and the solution circulation ratio are listed in Table 2.

- The effectiveness of the generator inlet temperature (solar source) is a factor of the largest effect to the COP. The difference was 0.1401, 27.4%.
- The chilled water inlet temperature (underground water) T16 is the second largest effect to the COP. The difference between the maximum and the minimum value is 0.0865 and the relative difference is 18.9 % with cooling capacity 12 kW.
- The influence of evaporator temperature to the COP is also minimal with only 2.2 % difference.
- The influence of absorber temperature and condenser temperature to the COP are almost identical, the relative difference is 19.2% and 18.9% respectively.

5. CONCLUSION

A simulation model was developed to calculate the performance of the aqua-ammonia vapour absorption system. An application of the model to evaluate the influence of the system parameters to its COP proved that the model can be used to analyse the effects of any changes to the parameters of the system Coefficient of Performance (COP). This may increase the COP value by more than 0.4 using a computer model as provided by [9]. The results show that the

complete system behaves with some unique characteristics. The selection of the generator temperature is a significant factor for achieving high system performance. Detailed improvement processes and their results are shown as very good operational maps under different working conditions. These maps are very important in the selection of the operating conditions for present systems or for planning new systems.

ACKNOWLEDGEMENTS

The author is highly grateful to department of mechanical engineering, higher institute of sciences and technology, Gharyan, Libya.

COMPETING INTERESTS

Authors have declared that no competing interests exist.

REFERENCES

1. Adel Akair, Absorption chiller cycle (NH₃-H₂O) Driven by Solar Energy, *IJMER-International Journal of Modern Engineering Research*, India; 2017.
2. Sumathy K, ZC Huang, ZF Li. Solar absorption cooling with low grade heat source a strategy of development in South China. *Solar Energy*. 2002;72(2):155-165.
3. Bravo D, González F, González J. Solar cooling in buildings. A state of the art. *Revista Ingeniería De Construcción*. 2018;33(2):115-126.
4. Bravo Hidalgo, D, Jiménez Borges, R, Valdivia Nodal Y. Applications of solar energy: History, sociology and last trends in investigation. *Production+ Limpia*. 2018;13(2):21-28.
5. Adel Akair, Hesham Baej. The effects of difference temperatures on various cycle parameters of ammonia -water absorption chiller when energised from a low temperature source. *Second Conference for Engineering Sciences and Technology (CEST-2019)*; Libya; 2019.
6. SimTech, Simulation and Technology. IPSEpro process simulator manuals: process simulation environment. SimTech Simulation Technology®; 2003c.
7. SimTech, Simulation and Technology. IPSEpro process simulator manuals: Model Development Kit. SimTech Simulation Technology®; 2003b.
8. Ashrae and Handbook. Absorption cooling, heating, and refrigeration equipment. *Refrigeration systems and applications*. Atlanta; 1994.
9. Ashrae and Handbook Fundamentals (SI). *American Society of Heating, Refrigerating and Air-conditioning Engineers*. Atlanta; 1989.
10. Wang J, Dai Y Gao L, Ma S. A new combined cooling, heating and power system driven by solar energy, *Renewable Energy*. 2009;34(12):2780-2788.
11. Herold KHR, Klein S. *Absorption Chillers and Heat Pumps*. Florida: CRC Press INC. 1996.
12. Solar and Next. Absorption Kits - NH₃; 2012. Available:http://www.solarnext.eu/eng/prod/chillii_abs_kits_nh.shtml

© 2021 Akair and Baej; This is an Open Access article distributed under the terms of the Creative Commons Attribution License (<http://creativecommons.org/licenses/by/4.0>), which permits unrestricted use, distribution, and reproduction in any medium, provided the original work is properly cited.

Peer-review history:

*The peer review history for this paper can be accessed here:
<http://www.sdiarticle4.com/review-history/65029>*