



Applied Artificial Intelligence

An International Journal

ISSN: (Print) (Online) Journal homepage: <https://www.tandfonline.com/loi/uaai20>

Optimizing Electromagnetic Cigarette Heaters Using PSO-NSGA II Algorithm: An Effective Strategy to Improve Temperature Control and Production Rate

Jifan Xu, Yan Chen, Henbing Yan & Xuesong Yang

To cite this article: Jifan Xu, Yan Chen, Henbing Yan & Xuesong Yang (2023) Optimizing Electromagnetic Cigarette Heaters Using PSO-NSGA II Algorithm: An Effective Strategy to Improve Temperature Control and Production Rate, Applied Artificial Intelligence, 37:1, 2222257, DOI: [10.1080/08839514.2023.2222257](https://doi.org/10.1080/08839514.2023.2222257)

To link to this article: <https://doi.org/10.1080/08839514.2023.2222257>



© 2023 The Author(s). Published with license by Taylor & Francis Group, LLC.



Published online: 07 Jun 2023.



Submit your article to this journal [↗](#)



View related articles [↗](#)



View Crossmark data [↗](#)



Optimizing Electromagnetic Cigarette Heaters Using PSO-NSGA II Algorithm: An Effective Strategy to Improve Temperature Control and Production Rate

Jifan Xu, Yan Chen, Henbing Yan, and Xuesong Yang

Faculty of Information Engineering and Automation, Kunming University of Science and Technology, Kunming, Yunnan, China

ABSTRACT

The global tobacco industry has made significant strides in reducing the harmful emissions of tobacco by focusing on the development of non-burning cigarette products. Among these innovations, electrically heated noncombustible cigarette smoking sets have garnered attention. However, one of the challenges faced by these products is the reliance on empirical values for temperature control, resulting in subpar taste and low production rates. To address these issues, this research introduces an optimization strategy that utilizes advanced algorithms such as Particle Swarm Optimization (PSO) and traditional non-dominated sorting genetic algorithm-II (NSGA-II). By leveraging these algorithms, this study aims to optimize the performance of electrically heated noncombustible cigarette smoking sets. The research methodology encompasses a comprehensive review of relevant literature and the systematic introduction of a simulation method. Through the proposed approach, a finite element model verification is conducted, which demonstrates a minimal maximum relative error between the model values of the objective function and the simulation values of the optimized parameters. As a result, this multi-objective optimization approach proves to be highly effective in enhancing the performance of electromagnetic cigarette heaters. It not only addresses the taste and production rate issues associated with existing electrically heated noncombustible cigarette smoking sets but also provides a scientifically grounded method for optimizing these devices. This research paves the way for further advancements in the tobacco industry, contributing to the development of safer and more satisfying alternatives to traditional cigarettes.

ARTICLE HISTORY



Received 26 April 2023

Revised 19 May 2023

Accepted 22 May 2023

Introduction

In the last few years, an increasing number of consumers have turned to alternative tobacco products as traditional tobacco has been deemed harmful and public smoking has been prohibited worldwide. These new products are

CONTACT Jifan Xu  m15812050258@163.com  Faculty of Information Engineering and Automation, Kunming University of Science and Technology, Kunming 650504, Yunnan, China

© 2023 The Author(s). Published with license by Taylor & Francis Group, LLC.

This is an Open Access article distributed under the terms of the Creative Commons Attribution License (<http://creativecommons.org/licenses/by/4.0/>), which permits unrestricted use, distribution, and reproduction in any medium, provided the original work is properly cited. The terms on which this article has been published allow the posting of the Accepted Manuscript in a repository by the author(s) or with their consent.

designed to reduce harm, eliminate side stream smoke, and fulfill physiological needs. Among these products, the electric heating cigarette is the most popular, as it heats tobacco at low temperatures to prevent the release of harmful components like CO and tar (Aszyk et al. 2018; de Falco et al. 2020; Soulet and Sussman 2022b). Induction heating is a technology that is both eco-friendly and commonly utilized in both industrial and household settings due to its non-contact heating and high efficiency in converting heat. Electric heating noncombustible cigarettes are composed of both electric heating fittings and a new type of cigarette (Guo et al. 2021; Kannan, Fisher, and Birgersson 2021; Narimani, da Silva, and Mukherjee 2020). The temperature control system includes a heating element, detection module, control module, output module, and power module (Soulet and Sussman 2022a). The control module receives electricity from the power module and directs voltage to the heating element, rapidly increasing its temperature to heat the cigarettes (Hao, Luo, and Pan 2021; Primavessy et al. 2021; Singh et al. 2021).

The electric heating non-burning cigarette smoking set has two stages of temperature control: preheating and constant temperature (Cheng et al. 2022). The preheating stage heats the cigarette to the set temperature, providing heat for the electrically heated unburned cigarette to bake the tobacco (Pavithra et al. 2022). To minimize wait time for users and prevent burning, the preheating stage should take no longer than 20 seconds and have a fast-heating rate. During the constant temperature stage, the electrically heated noncombustible cigarette is roasted to produce smoke (Li et al. 2020). To ensure proper baking in the next smoking action, the temperature control system must swiftly increase the temperature to the preset level when it drops below. The baking effect of tobacco shreds by smoking utensils is influenced by the heating rate during the preheating stage, temperature stability in the constant temperature stage, and accuracy of temperature measurement (Guo et al. 2019; He et al. 2018; Zhai et al. 2019).

Compared to conventional resistance heating, electromagnetic cigarette heaters offer fast thermal response, uniform heating, and easy automatic control for heating special cigarettes. Achieving the desired target temperature of tobacco material quickly is crucial for consumers' smoking experience evaluation when using electromagnetic cigarette heaters (DeRousseau, Kasprzyk, and Srubar 2021). The temperature distribution on the heating element is greatly influenced by the current frequency and current intensity of the electromagnetic heating component. Most smoking appliances on the market have heating elements made of high permeability metal materials, and their heating process is similar to that of induction heating of steel materials. However, previous studies (such as reference (Ridha et al. 2021)) have only considered the influence of one parameter at a time on the temperature field distribution without considering the coupling between induction heating parameters. Other

studies (such as reference (de Falco et al. 2020) and (Narimani, da Silva, and Mukherjee 2020)) used different optimization methods, such as multi-objective genetic algorithm or artificial neural network, to optimize induction heating parameters, but these methods only optimized the temperature of the metal workpiece without considering the tobacco material inside the cigarette.

The electromagnetic cigarette heater is a nonlinear coupled heat transfer system consisting of an electromagnetic field, temperature field, and circuit. It undergoes complex magnetothermal coupling during heating and is a time-varying multivariate nonlinear function (She et al. 2021). Achieving an optimal temperature distribution on the heater is crucial, and to do so, it's important to globally optimize the induction heating parameters. This study proposes a multi-objective genetic algorithm that is based on Particle Swarm Optimization and an improved NSGA-II algorithm to optimize the temperature field distribution characteristics of electromagnetic heaters. Unlike existing research that adjusts temperature control parameters individually, this approach provides a more efficient solution by optimizing the parameters globally. This is especially important in mass production, where individual parameter adjustment is time-consuming and inefficient, leading to a low qualified rate. Therefore, studying the temperature control system of new tobacco products is essential to improve the qualification rate of cigarette products and accelerate the development of new tobacco products in China.

Review of the Previous Studies

The State Tobacco Monopoly Bureau of China has identified the development of new cigarette products as a key focus of tobacco development in the country, as the industry rapidly evolves. In 2014, a major project was launched to develop new cigarettes, including electric heating noncombustible products.

Market research shows that most global manufacturers of new cigarette products are concentrated in Shenzhen, with an output share of 70% of the global market. Shenzhen has developed a comprehensive industrial chain, encompassing product design, assembly, manufacturing, and related suppliers. However, due to foreign technical barriers, there is a lack of relevant literature on the key technologies of new cigarette products. Furthermore, China started researching new cigarettes later than other countries, and while temperature-controlled smoking tools have been developed abroad, research on electric heating noncombustible cigarette smoking tools has only just begun in China. There are currently no well-known new tobacco products in China, with most processing done by foreign countries. The temperature sensitivity of electric heating noncombustible cigarette smoking tools remains largely unexplored, and foreign technical barriers have hampered progress in China's research efforts. At present, the temperature

control system for China's electric heating non-burning cigarettes relies mainly on Pulse Width Modulation (PWM), which adjusts the duty ratio of a PWM wave to control the heating time of the power supply voltage for the heating module.

When the control module detects the resistance value of the heating element, it calculates the corresponding temperature of the heating element according to the resistance value, and then uses the difference between the temperature and the preset temperature to perform PID (Proportion Integration Differentiation) operation, and then adjusts the output PWM to control the temperature so as to meet the requirements (DeRousseau, Kasprzyk, and Srubar 2021; He et al. 2018). In recent years, some scholars have designed the structure and overall function of smoking utensils (DeRousseau, Kasprzyk, and Srubar 2021). Chongqing China Tobacco Industry Co., Ltd. has solved the problem of high temperature of the outer wall of new cigarette smoking utensils by designing the structure and appearance of smoking utensils (Ridha et al. 2021). Some scholars have studied the harmfulness of tobacco leaves (de Falco et al. 2020) and the thermal behavior of tobacco materials under the condition of thermal cracking (Kannan, Fisher, and Birgersson 2021), and the research on the use function of electric heating incombustible cigarette products is also common. At present, most of the research on electric heating noncombustible cigarette products in China focuses on the toxicological analysis, structure, appearance and function of cigarettes (She et al. 2021), but it is rare to study the stability influencing factors and key parameters of temperature control system for electric heating noncombustible cigarettes. The design parameters of most electric heating non-burning new cigarette smoking sets in China are designed only by engineers' experience. In the temperature control system, the basic parameters of key heating elements, such as initial resistance, are selected only by experience, and their resistance values at room temperature are between 0.53, lacking theoretical research support. Most smoking sets have large temperature fluctuations, uneven heating of cigarettes, and large fluctuations in smoking taste.

The research gaps in the discussed study can be identified as follows:

- (1) Lack of Temperature Control Optimization: The reliance on empirical values for temperature control in electrically heated noncombustible cigarette smoking sets suggests a gap in optimizing this crucial aspect. The study aims to fill this gap by introducing an optimization strategy using advanced algorithms.
- (2) Subpar Taste and Low Production Rates: The mentioned challenge of subpar taste and low production rates in electrically heated noncombustible cigarette smoking sets indicates a need for improvement. The research aims to address these issues through the proposed

optimization strategy, but the specific gaps within the existing methods and technologies are not explicitly mentioned.

- (3) Limited Scientifically Grounded Optimization Methods: The research highlights the importance of providing a scientifically grounded method for optimizing electrically heated noncombustible cigarette smoking sets. This implies a potential gap in the current scientific literature regarding effective optimization approaches for such devices.
- (4) Limited Validation and Verification Studies: The mention of conducting a finite element model verification to validate the proposed approach suggests a potential gap in existing research regarding comprehensive validation and verification studies for optimizing electromagnetic cigarette heaters.

By identifying these research gaps, the study aims to contribute to the existing knowledge and address the limitations in optimizing electrically heated noncombustible cigarette smoking sets, ultimately leading to the development of safer and more satisfying alternatives to traditional cigarettes.

As mentioned above, the existing research work of electrically heated noncombustible cigarette smoking sets mainly adjusts the corresponding temperature control parameters one by one according to the temperature control effects of different smoking sets, and solves the problem of inaccurate temperature control of electrically heated cigarette smoking sets in production practice. It requires a large number of skilled engineers to adjust the parameters one by one in the production line according to the temperature control effects, resulting in low qualified rate and low efficiency in mass production. In order to rapidly and stably develop the new cigarette products industry in China and improve the qualified rate of cigarette products in mass production, it is necessary to study the temperature control system of new tobacco products.

Method and Algorithm Theory

The proposed algorithm, which combines Particle Swarm Optimization (PSO) and non-dominated sorting genetic algorithm-II (NSGA-II), offers several advantages and disadvantages in the optimization of electromagnetic cigarette heaters. Let's discuss them in detail:

Advantages:

- (1) Improved Optimization Performance: PSO and NSGA-II are both well-established optimization algorithms known for their effectiveness in solving complex problems. By combining these algorithms, the proposed approach benefits from their complementary strengths. PSO excels in exploring the search space efficiently and quickly converging

to optimal solutions, while NSGA-II excels in maintaining a diverse set of solutions and providing a trade-off between conflicting objectives. This combination enhances the optimization performance and increases the likelihood of finding high-quality solutions.

- (2) **Multi-Objective Optimization:** The proposed algorithm is designed for multi-objective optimization, which is crucial when dealing with conflicting objectives. In the context of electromagnetic cigarette heaters, there are multiple parameters to optimize, such as temperature control, taste, and production rates. The multi-objective nature of the algorithm allows for the simultaneous consideration of these objectives and the generation of a set of Pareto-optimal solutions that represent different trade-offs between them. This provides decision-makers with a range of optimized solutions to choose from based on their specific requirements.
- (3) **Scientifically Grounded Methodology:** The proposed algorithm is built upon a solid scientific foundation. The research encompasses a thorough review of relevant literature and the systematic introduction of a simulation method. This ensures that the optimization process is based on a comprehensive understanding of the underlying principles and factors affecting the performance of electromagnetic cigarette heaters. By incorporating scientific rigor, the proposed algorithm increases the confidence in its results and provides a reliable framework for optimizing these devices.

Disadvantages:

- (1) **Computational Complexity:** The combination of PSO and NSGA-II algorithms may increase the computational complexity of the optimization process. Both algorithms require a considerable number of iterations and evaluations of the objective functions to converge to optimal solutions. This can result in longer computational times, especially when dealing with complex electromagnetic models or a large number of optimization parameters. It is essential to consider the computational resources and time constraints when applying the proposed algorithm.
- (2) **Algorithm Parameter Tuning:** Both PSO and NSGA-II algorithms have specific parameters that need to be set appropriately to ensure their optimal performance. Tuning these parameters can be a challenging task, as their effectiveness may vary depending on the specific problem being addressed. The proper selection of parameters, such as swarm size, inertia weight, mutation rate, and crossover rate, is crucial for achieving good convergence and diversity in the solutions. Careful experimentation and fine-tuning of these parameters are necessary to maximize the algorithm's performance.

(3) **Dependency on Simulation Accuracy:** The proposed algorithm relies on accurate simulation models to evaluate the objective functions and determine the fitness of solutions. Any discrepancies or inaccuracies in the simulation models can affect the optimization process and lead to suboptimal results. It is important to ensure that the simulation models used in the algorithm are validated and representative of the real-world behavior of electromagnetic cigarette heaters. Continuous validation and refinement of the simulation models are necessary to minimize any potential discrepancies.

In summary, the proposed algorithm offers advantages such as improved optimization performance, multi-objective capability, and a scientifically grounded methodology. However, it also presents challenges in terms of computational complexity, parameter tuning, and reliance on accurate simulation models. These factors need to be carefully considered and managed to leverage the benefits of the algorithm effectively.

Establishment of the Simulation Model

Self-developed electric heating new cigarette smoking set consists of power supply module, heating control module, display module and heating cup. The main control circuit design of STM32F030 is the core part of the whole temperature-controlled electronic cigarette design; Make full use of the processing power and stability of efficient kernel system. Its hardware circuit diagram is shown in Figure 1.

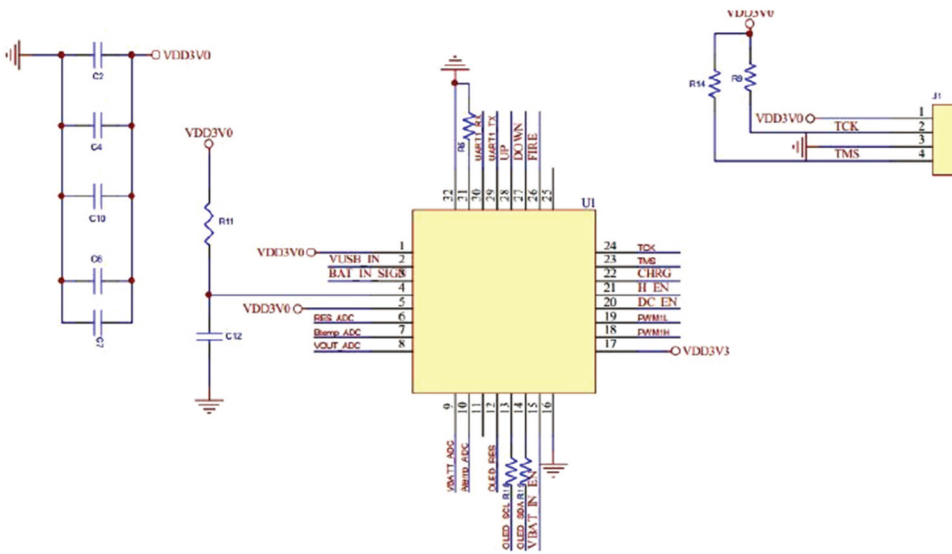

Figure 1. Electric heating new cigarette smoking set.

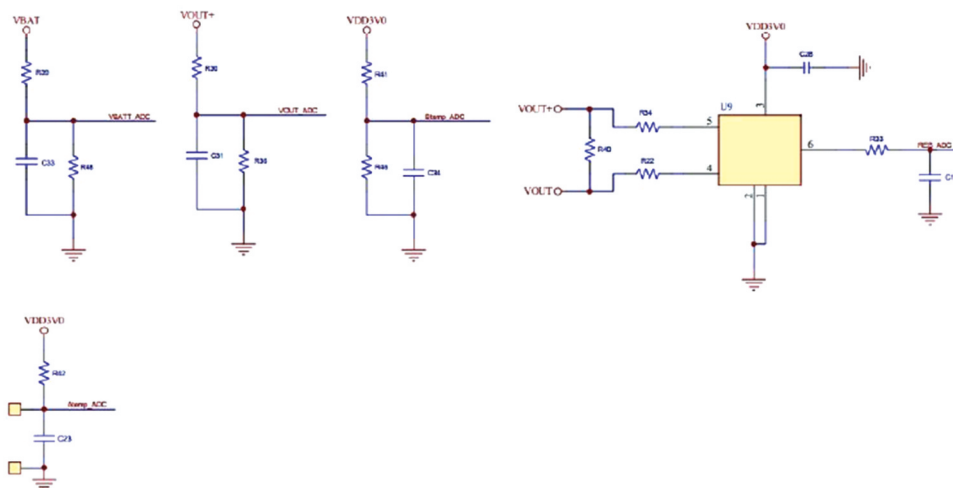

Figure 2. Hardware circuit of detection module.

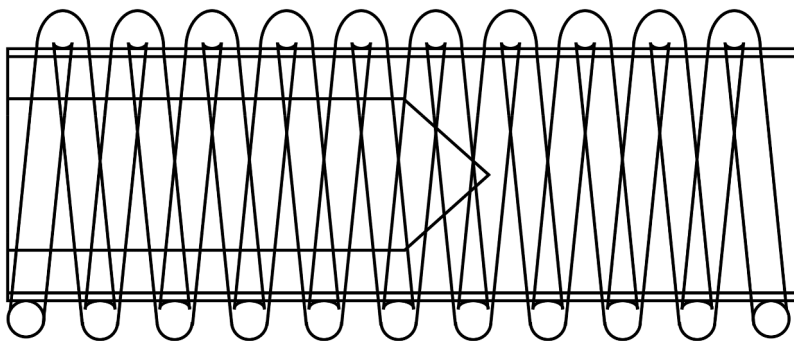

Figure 3. Schematic diagram of electromagnetic induction heating.

Figure 2 shows the design of the hardware circuit of the detection module, which mainly converts the temperature signal into the voltage signal through the temperature sensor, and compares the voltage through the reference voltage of the IO port, resulting in the voltage difference which is input into the main control MCU unit for temperature control. Under the inversion effect of the smoke oscillation module, alternating current is introduced into the electromagnetic coil, which will generate a high-frequency alternating magnetic field around the ferromagnetic metal inductor. The changed magnetic field makes the surface of the metal inductor form layers of eddy currents.

Under the thermal effect of the eddy currents, the surface temperature of the metal inductor rises rapidly, and then the tobacco material is heated. The heating principle is shown in Figure 3. The metal inductor is located inside the smoking article, and the heat (from the metal

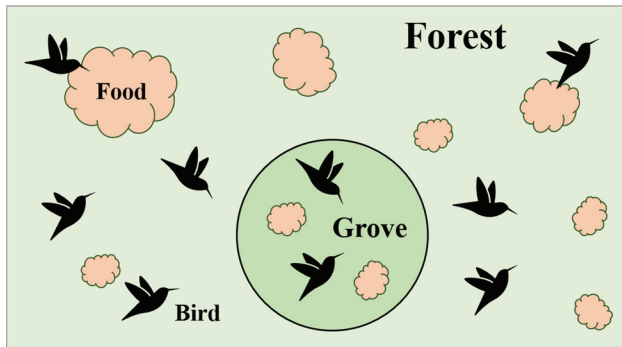

Figure 4. Schematic diagram of PSO algorithm model.

inductor) heats the smoking article based on the heat conduction principle.

Theory of PSO Algorithm

In 1995, James Kennedy and Russell Eberhart developed a simplified algorithm model inspired by the regular feeding behavior of birds. After years of improvements, it evolved into the Particle Swarm Optimization (PSO) algorithm, also known as the Particle Swarm Algorithm.

The PSO algorithm has the advantages of fast convergence speed, fewer parameters, and simple implementation (it converges faster to the optimal solution for high-dimensional optimization problems than genetic algorithms). However, it can also suffer from the problem of getting stuck in local optimal solutions. The idea of the PSO algorithm originated from the study of bird feeding behavior. Birds use collective information sharing to find the optimal destination for the group.

Imagine this scenario in [Figure 4](#): a flock of birds is randomly searching for food in a forest. They want to find the location with the most amount of food. However, none of the birds know exactly where the food is located, they can only sense the general direction of the food. Each bird searches in the direction it perceives and records the location where it has found the largest amount of food during the search. Additionally, all the birds share the locations and amount of food they have discovered during their search, so the flock can know where the most food is currently located.

During the search, each bird adjusts its search direction based on the location with the largest amount of food that it remembers and the location with the largest amount of food recorded by the flock. After a period of searching, the flock can find the location in the forest with the largest amount of food (the global optimum). The PSO algorithm starts with a set of random particles (random solutions) and iteratively finds the optimal solution. During

each iteration, particles update themselves by tracking two extreme values. The first extreme value is the best solution found by the particle itself, called the personal best (pbest). The second extreme value is the best solution found in the entire population, known as the global best (gbest).

Discussion About the Traditional PSO-NSGA II-Based Algorithm

Non-dominated sorting genetic algorithm Non-dominated sorting genetic algorithm-II (NSGA-II) puts forward a fast non-dominated sorting algorithm, and introduces the elite strategy to avoid the loss of excellent individuals in the process of evolution, so as to obtain a better design; By using congestion degree and congestion degree comparison operator, the population is rich in the evolution process, which makes up for the deficiency of the original algorithm and improves the operation speed and robustness of the algorithm. There is no unique global optimal solution for multi-objective optimization problems, but a set of optimal solutions, which is called Pareto optimal solution. In this paper, the multi-objective optimization problem of electromagnetic cigarette heater takes the output temperature and rising time of the heating element in the electromagnetic heating assembly as the objective function, and obtains the Pareto solution set with the output temperature in the range of 335 to 375°C and fast response speed (i.e. short rising time) by globally searching the electromagnetic parameters(I, f) in PSO.

The NSGA-II algorithm divides the evolutionary population into several layers according to the dominant relationship: the first layer is the set of non-dominant individuals of the evolutionary population; The second layer is the set of non-dominated individuals obtained by removing the first layer of individuals in the evolutionary population; The third layer selects by analogy according to the size of the individual layer, that is, the frontier value. The earlier the layer is, the higher the priority will be, and the individuals in the same layer will be judged by the crowding degree until the number of individuals reaches the set population size. However, the NSGA-II algorithm still has some defects, for example, its running efficiency is low and its accuracy is low when facing the objective function with high complexity.

Optimization Strategy of the PSO-NSGA II-Based Algorithm

In this paper, an improved NSGA-II algorithm is proposed to improve the operation speed and efficiency of the algorithm. In the genetic process, its crossover probability operator obeys the normal distribution, and the mutation probability will be self-adaptively adjusted with the fitness evaluation function of individual population, so as to enrich the diversity of the population as much as possible while keeping the excellent genes of individual population to the maximum extent.

The selection of constants such as crossover and p values in a study is an important aspect that can impact the results and conclusions. Choosing these constants is typically based on a combination of empirical evidence and theoretical considerations.

Specifically, crossover and mutation operators are fundamental components of evolutionary algorithms for searching and optimizing solutions. The choice of crossover operator determines how genetic material is exchanged between individuals in the population, while the mutation operator introduces small random changes to the genetic material. Both operators influence the exploration and exploitation capabilities of the algorithm.

In the literature, the selection of crossover and mutation operators, as well as their associated parameters, often involves experimentation and analysis. Researchers typically consider previous studies that have explored different variations of these operators and assess their performance on benchmark problems or real-world scenarios.

The selection process can involve conducting pilot experiments or using established best practices in the field. Researchers may try different operators and parameter settings combinations to find a balance between exploration (diversification) and exploitation (intensification) within the evolutionary algorithm. They analyze the performance metrics, such as convergence speed, solution quality, and computational efficiency, to evaluate the effectiveness of different choices.

Furthermore, the choice of crossover and mutation parameters may also depend on the characteristics of the problem domain. For example, the population size, mutation rate, and crossover probability can be adjusted based on the size and complexity of the problem, the desired level of exploration, and the computational resources available.

It is worth noting that selecting these constants is not always a straightforward task, and there may not be a universally optimal choice. Different problems and domains may require specific configurations to achieve the best performance. Hence, it is common for researchers to provide justifications for their choices based on their experience, insights from previous studies, and the problem at hand.

In summary, the selection of constants such as crossover and p values in evolutionary computation research is typically based on a combination of empirical experimentation, analysis of performance metrics, insights from previous studies, and considerations specific to the problem domain. Researchers aim to find a configuration that balances exploration and exploitation, considering the problem's characteristics and available computational resources.

The basic process of the improved NSGA-II algorithm can be summarized as follows:

- (1) randomly generating an initial parent population P_t with a population size of M , encoding individual genes of the population in a real number encoding mode, and performing decoding operation to calculate individual values on each objective function;
- (2) Based on the values of population individuals in each objective function, the parent population P_t is sorted quickly and non-dominated, and the frontier where individuals are located is assigned a *rank* value, and the crowding degree of individuals is calculated;
- (3) According to the tournament mechanism, $M/2$ individuals are selected from the parent population P_t to form a paired population, and the normal distribution crossover operator is used to adaptively adjust the mutation operator to generate the offspring population Q_t with the size of N , and the parent population P_t and the offspring population Q_t are merged into a population with the size of $2M$;
- (4) The merged population is sorted in a non-dominated way, and M individuals are selected to form a population to replace the parent population P_t based on the *rank* value and crowding degree of each individual in the population;
- (5) Repeat the above steps until the termination conditions are met.

Introducing Normal Distribution Crossover Operator

In the process of population evolution, the traditional crossover operator realizes information exchange between individuals with a fixed probability, which makes individuals only solve in a small search space, and the sampling space is small, so the Pareto solution set obtained is easy to fall into local optimum. Therefore, the traditional crossover operator can be improved to encode the population individuals with real numbers, assuming that there are parent individuals p_1 and p_2 in the population, and the offspring individuals x_1 and x_2 can be obtained through the normal distribution crossover operator, where i represents the i th variable of individual chromosome gene string.

① Randomly generate a number p_0 in the range of $(0,1)$

② Compare the relationship between p and the given cross probability threshold p_m , taking $p_m = 0.5$ as an example.

If $p < 0.5$, then:

$$\begin{aligned} x_{1,i} &= \frac{p_{i,1} + p_{2,i}}{2} + \frac{1.481(p_{i,1} - p_{2,i})|N(0, 1)|}{2} \\ x_{2,i} &= \frac{p_{i,1} + p_{2,i}}{2} - \frac{1.481(p_{i,1} - p_{2,i})|N(0, 1)|}{2} \end{aligned} \quad (1)$$

If $p > 0.5$, then:

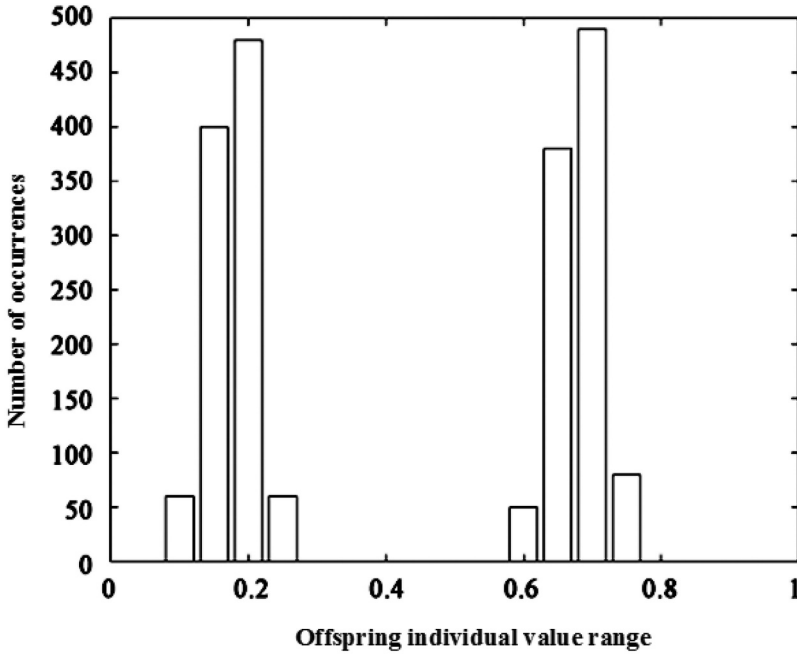

Figure 5. Spatial distribution of traditional crossover operator search.

$$\begin{aligned}
 x_{1,i} &= \frac{p_{i,1} + p_{2,i}}{2} - \frac{1.481(p_{i,1} - p_{2,i})|N(0, 1)|}{2} \\
 x_{2,i} &= \frac{p_{i,1} + p_{2,i}}{2} + \frac{1.481(p_{i,1} - p_{2,i})|N(0, 1)|}{2}
 \end{aligned} \tag{2}$$

Where $|N(0,1)|$ represents a random variable that obeys the standard normal distribution.

In the one-dimensional search space, the traditional crossover operator and the normal distribution crossover operator are respectively used to carry out genetic operations on individuals, and the given two parent individuals are crossed 1000 times to generate 2000 offspring individuals, and the distribution of offspring individuals in the search space is compared. The given two parent individuals are crossed 1000 times, and the initial values of parent individuals p_1 and p_2 are set to 0.7 and 0.2 respectively. The distribution of the crossover operator search space is shown in Figures 5 and 6.

The value range of new individuals obtained by normal distribution crossover operator is $(-1.5, 3.5)$, while the value range of new individuals obtained by simulating binary crossover operator is $(0.1, 0.8)$. Obviously, the new individuals obtained by normal distribution crossover operator have more uniform distribution and wider search space.

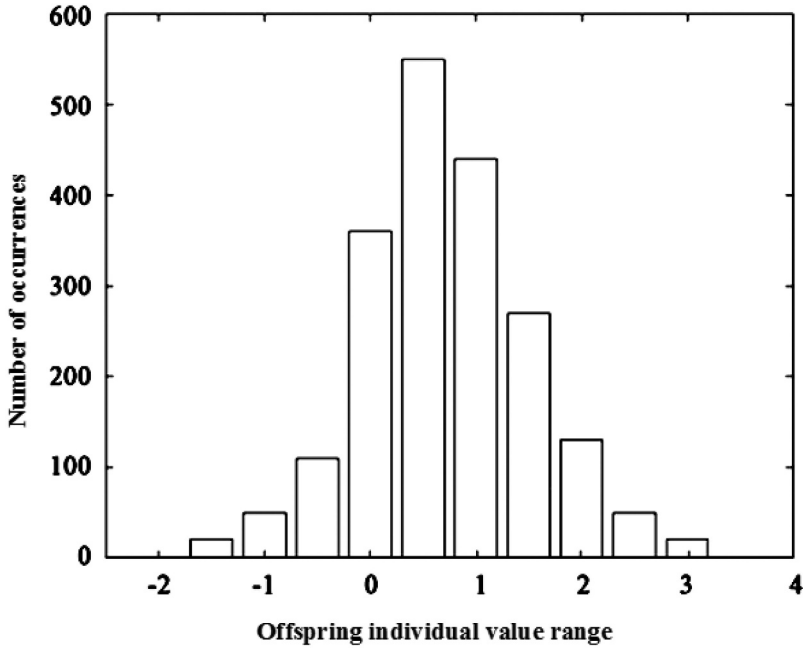

Figure 6. Search space distribution of normal distribution crossover operator.

Adaptive Adjustment of Mutation Operator

The mutation operation of the traditional NSGA-II algorithm mostly adopts polynomial mutation mode, which is subjective and has poor convergence performance. By adjusting the compilation mode, the convergence speed of the population evolution process can be improved and the population diversity can be enhanced. The operation process of adaptive adjustment mutation operator is as follows:

The individual variation probability $P_m(x_i)$ is expressed as

$$\begin{aligned}
 P_m(x_i) &= 2 \times \bar{P}_m - e(x_i), \\
 e(x_i) &= \frac{E(x_i)}{\sum_{j=1}^M E(x_j)} M \bar{P}_m. \\
 \bar{P}_m &= \frac{1}{M} \sum_{j=1}^M P_m(x_j),
 \end{aligned} \tag{3}$$

Where $e(x_i)$ is the fitness of the individual x_i , $E(x_i)$ is the fitness evaluation function of the individual x_i , $P_m(x_i)$ is the mutation probability of the individual x_i , \bar{P}_m is the average mutation probability, and M is the size of the population.

The mathematical expressions explained as follows:

- (1) The first equation states that the Pareto solution result for the variable x subscript i ($P_m(x_i)$) is equal to 2 multiplied by the mean Pareto solution (\bar{P}_m) for variable x subscript i , subtracted by the value of e subscript i . Here, e_i represents the error term associated with the variable x subscript i .
- (2) The second equation defines the error term e_i as the expectation value (E) of variable x subscript i , divided by the sum of the expectation values of all variables x subscript j (j ranging from 1 to M) multiplied by the mean Pareto solution for variable x subscript i ($\bar{P}_m(x_i)$).
- (3) The third equation expresses the mean Pareto solution for variable x subscript i ($\bar{P}_m(x_i)$) as the reciprocal of M (the total number of variables) multiplied by the sum of the Pareto solution results for variable x subscript j (j ranging from 1 to M).

In summary, these equations describe the relationship between the Pareto solution results, mean Pareto solutions, and error terms associated with each variable in a research context.

According to the above formula, the mutation probability of individuals with larger fitness is relatively small, and the excellent genes in the population are maintained to the greatest extent. On the contrary, for the inferior individuals in the population, the mutation probability should be improved as much as possible, which can not only enrich the diversity of the population, but also accelerate the convergence speed of the population evolution process.

Optimization Results and Analysis of NSGA-II

Multi-objective optimization is a common problem in reality. Compared with single-objective optimization, the biggest characteristics of multi-objective optimization are conflict and incommensurability. Conflict means that the improvement of one sub-goal may cause the performance of another or several other sub-goals to decrease, that is, there is no way to make all the goals achieve the best at the same time, so we can only make a compromise choice among them; Inconsistency refers to the fact that the dimensions of multiple targets cannot be directly compared horizontally. A common example is the contradiction between quality and efficiency in engineering, which requires a balanced solution.

According to the PSO prediction model, the values of population individuals on each objective function are calculated, and the improved NSGA-II algorithm is used to globally optimize the decision variables in the search space, and the Pareto solution set of multi-objective optimization of electromagnetic cigarette heater is obtained. In order to obtain better optimization results, the population size of NSGA-II is set to 300, the evolution generation is 200 (we have conducted convergence analysis during our experimentation to

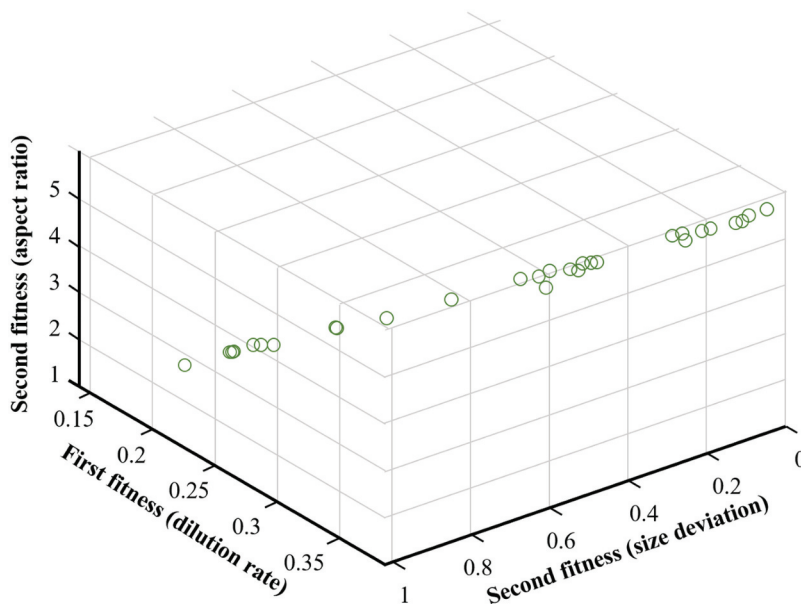

Figure 7. Pareto solution set of improved NSGA-II optimization.

determine the point at which the algorithm achieves satisfactory convergence. By monitoring the convergence behavior of the optimization algorithm over multiple iterations, we have observed that the algorithm's performance, in terms of finding high-quality solutions, stabilizes or plateaus after around 200 iterations. Further iterations do not lead to significant improvements or provide additional insights), the crossover probability threshold P_m and the average mutation probability \bar{P}_m are 0.8 and 0.05, respectively. The distribution of Pareto solution set obtained at the end of generation 200 is shown in [Figure 7](#).

Select three groups of optimized parameters (I, f) optimized by improved NSGA-II from [Figure 7](#) to decode, calculate their values in each objective function, and compare them with the simulation values obtained by the finite element model. It can be concluded that the model values of optimized parameters obtained by this model in each objective function have little error with the simulation values of the finite element model. In the next step, aiming at the multi-objective optimization method of the model, the latest and most advanced algorithm can be used to optimize the structure and parameters of NSGA-II algorithm, so as to obtain better optimization results. In addition, more multi-objective optimization algorithms (for example, multi-objective simulated annealing algorithm) can be introduced to further explore the multi-objective optimization method for laser direct deposition process parameters.

Conclusion

This paper presents a novel approach to globally optimize the induction heating parameters of an electromagnetic cigarette heater. The proposed method employs a multi-objective genetic algorithm based on PSO and an improved NSGA-II algorithm. The training samples are generated by the finite element software Comsol using a smoking set simulation model. COMSOL Multiphysics® Version 6.1 is a widely used commercial Finite Element Analysis (FEA) software that enables engineers and researchers to simulate and analyze various physical phenomena. It stands for “COMputational SOLutions” and offers a comprehensive set of tools for modeling, simulating, and optimizing systems involving multiple physics domains. COMSOL allows users to solve complex multiphysics problems by coupling different physics phenomena, such as heat transfer, fluid flow, structural mechanics, and electromagnetics.

First, a PSO model is established to optimize the output temperature and rising time of the heating element of the smoking set. The kernel parameters and penalty factors are then optimized using a genetic algorithm. The output of the predicted model is considered as the objective function to be optimized by the improved NSGA-II algorithm, which calculates the Pareto solution set. To obtain better optimization results, under the optimal parameters, the crossover probability threshold P_m is 8 and the average mutation probability P_m is 0.05. Furtherly, the results show that the error between the optimized parameters and the finite element model is minimal, indicating the effectiveness of this method. Compared to traditional methods, this approach can optimize multiple objective functions and search the entire search space in parallel, overcoming the issue of many traditional methods falling into local optimization.

Disclosure statement

No potential conflict of interest was reported by the author(s).

Funding

This research received no specific grant from any funding agency in the public, commercial, or not-for-profit sectors.

References

- Aszyk, J., P. Kubica, J. Namieśnik, A. Kot-Wasik, and A. Wasik. 2018. New approach for e-cigarette aerosol collection by an original automatic aerosol generator utilizing melt-blown non-woven fabric. *Analytica Chimica Acta* 1038:67–78. doi:10.1016/j.aca.2018.08.015.
- Cheng, C.-W., H.-S. Kou, S.-M. Wu, and C.-C. Wang. 2022. A chemometric experimental design with three-step stacking capillary electrophoresis for analysis of five tobacco-specific nitrosamines in cigarette products. *Journal of Chromatography A* 1677:463283. doi:10.1016/j.chroma.2022.463283.
- de Falco, B., A. Petridis, P. Paramasivan, A. D. Troise, A. Scaloni, Y. Deeni, W. E. Stephens, and A. Fiore. 2020. Reducing toxic reactive carbonyl species in e-cigarette emissions: Testing a harm-reduction strategy based on dicarbonyl trapping. *RSC Advances* 10 (36):21535–44. doi:10.1039/D0RA02138E.
- DeRousseau, M. A., J. R. Kasprzyk, and W. V. Srubar III. 2021. Multi-objective optimization methods for designing low-carbon concrete mixtures. *Frontiers in Materials* 8:680895. doi:10.3389/fmats.2021.680895.
- Guo, J., J. Ikuemonisan, D. K. Hatsukami, and S. S. Hecht. 2021. Liquid chromatography-nanoelectrospray ionization-high-resolution tandem mass spectrometry analysis of apurinic/apyrimidinic sites in oral cell DNA of cigarette smokers, e-cigarette users, and nonsmokers. *Chemical Research in Toxicology* 34 (12):2540–48. doi:10.1021/acs.chemrestox.1c00308.
- Guo, Y., H. Yang, M. Chen, J. Cheng, and D. Gong. 2019. Ensemble prediction-based dynamic robust multi-objective optimization methods. *Swarm and Evolutionary Computation* 48:156–71. doi:10.1016/j.swevo.2019.03.015.
- Hao, J., S. Luo, and L. Pan. 2021. Computer-aided intelligent design using deep multi-objective cooperative optimization algorithm. *Future Generation Computer Systems* 124:49–53. doi:10.1016/j.future.2021.05.014.
- He, G., T. Zhang, F. Zheng, and Q. Zhang. 2018. An efficient multi-objective optimization method for water quality sensor placement within water distribution systems considering contamination probability variations. *Water Research* 143:165–75. doi:10.1016/j.watres.2018.06.041.
- Kannan, V., A. Fisher, and E. Birgersson. 2021. Monte Carlo assisted sensitivity analysis of a Li-ion battery with a phase change material. *Journal of Energy Storage* 35:102269. doi:10.1016/j.est.2021.102269.
- Li, Y., A. E. Burns, G. J. P. Burke, M. E. Poindexter, A. K. Madl, K. E. Pinkerton, and T. B. Nguyen. 2020. Application of high-resolution mass spectrometry and a theoretical model to the quantification of multifunctional carbonyls and organic acids in e-cigarette aerosol. *Environmental Science & Technology* 54 (9):5640–50. doi:10.1021/acs.est.9b07387.
- Narimani, M., G. da Silva, and K. Mukherjee. 2020. Does ‘Dry Hit’ vaping of vitamin E acetate contribute to EVALI? Simulating toxic ketene formation during e-cigarette use. *Plos One* 15 (9):e0238140. doi:10.1371/journal.pone.0238140.
- Pavithra, M., R. Rajmohan, T. Ananth Kumar, S. Usharani, and P. Manju Bala. 2022. Investigation of energy optimization for spectrum sensing in distributed cooperative iot network using deep learning techniques. *Hybrid Intelligent Approaches for Smart Energy: Practical Applications* 6:107–27.
- Primavessy, D., J. Metz, S. Schnur, M. Schneider, C.-M. Lehr, and M. Hittinger. 2021. Pulmonary in vitro instruments for the replacement of animal experiments. *European Journal of Pharmaceutics and Biopharmaceutics* 168:62–75. doi:10.1016/j.ejpb.2021.08.005.
- Ridha, H. M., C. Gomes, H. Hizam, M. Ahmadipour, A. A. Heidari, and H. Chen. 2021. Multi-objective optimization and multi-criteria decision-making methods for optimal design of

- standalone photovoltaic system: A comprehensive review. *Renewable and Sustainable Energy Reviews* 135:110202. doi:[10.1016/j.rser.2020.110202](https://doi.org/10.1016/j.rser.2020.110202).
- She, C., R. Jia, B.-N. Hu, Z.-K. Zheng, Y.-P. Xu, and D. Rodriguez. 2021. Life cycle cost and life cycle energy in zero-energy building by multi-objective optimization. *Energy Reports* 7:5612–26. doi:[10.1016/j.egy.2021.08.198](https://doi.org/10.1016/j.egy.2021.08.198).
- Singh, A. V., R. S. Maharjan, C. Kromer, P. Laux, A. Luch, T. Vats, V. Chandrasekar, S. P. Dakua, and B.-W. Park. 2021. Advances in smoking related in vitro inhalation toxicology: A perspective case of challenges and opportunities from progresses in lung-on-chip technologies. *Chemical Research in Toxicology* 34 (9):1984–2002. doi:[10.1021/acs.chemrestox.1c00219](https://doi.org/10.1021/acs.chemrestox.1c00219).
- Soulet, S., and R. A. Sussman. 2022a. A critical review of recent literature on metal contents in E-Cigarette aerosol. *Toxics* 10 (9):510. doi:[10.3390/toxics10090510](https://doi.org/10.3390/toxics10090510).
- Soulet, S., and R. A. Sussman. 2022b. Critical review of the recent literature on organic byproducts in E-Cigarette aerosol emissions. *Toxics* 10 (12):714. doi:[10.3390/toxics10120714](https://doi.org/10.3390/toxics10120714).
- Zhai, Y., Y. Wang, Y. Huang, and X. Meng. 2019. A multi-objective optimization methodology for window design considering energy consumption, thermal environment and visual performance. *Renewable Energy* 134:1190–99. doi:[10.1016/j.renene.2018.09.024](https://doi.org/10.1016/j.renene.2018.09.024).